

(ko)

**LISTER STAR**

© 2015 Wahl Clipper Corporation

## IMPORTANT SAFEGUARDS

READ ALL INSTRUCTIONS AND SAFEGUARDS BEFORE USING THIS APPLIANCE. When using an electrical appliance, basic precautions should always be followed, including the following:

**DANGER:** To reduce the risk of electrical shock.

- 1) Do not reach for appliance that has fallen into water. Unplug immediately.
- 2) Do not use while bathing or in a shower, tub or sink. Do not place or drop into water or other liquid.
- 4) Always unplug this appliance from electrical outlet immediately after using.
- 5) Unplug this appliance before cleaning.

**WARNING:** To reduce the risk of burns, fire, electrical shock, or injury to person.

- 1) An appliance should never be left unattended when plugged in.
- 2) Close supervision is necessary when this appliance is used by, on or near children or invalids.
- 3) Use this appliance only for its intended use as described in this manual. Do not use attachments not recommended by manufacturer.
- 4) Never operate this appliance if it has a damaged cord or plug if it is not working properly, if it has been damaged or dropped in water. Return the appliance to Wahl Clipper Corporation for examination and repair.
- 5) Keep the cord away from heated surface.
- 6) Never operate this appliance with the air opening blocked or while on a soft surface, such as a bed or a couch, where the air openings may be blocked. Keep the air openings free of lint, hair and the like.
- 7) Never drop or insert any object into any opening.
- 8) Do not operate where aerosol (spray) products are being used, where oxygen is being administered or near flammable liquids, such as certain flammable blade lubricants or cleaning agents.
- 9) Do not use this appliance with damaged or broken comb, as injury may occur.
- 10) During use, do not place or leave appliance where it may be damaged by an animal or exposed to weather.
- 11) Certain sanitizing solutions and spray lubricants may cause stress crack damage to clippers. We recommend blade lubrication and cleaning with WAHL CLIPPER OIL ONLY.
- 12) To disconnect, turn all controls to "off," then remove plug from outlet.

# SAVE THESE INSTRUCTIONS

This clipper has been designed for household use.

## SETTING FOR HORSE AND CATTLE CLIPPING PREPARING THE ANIMAL

The clipper cannot be expected to cut properly if the animal is wet and dirty.

THE ANIMAL MUST BE CLEAN AND DRY.

Ideally, shampoo and rinse the coat a few days before clipping. The building floor should also be clean and dry.

Clip horses before the coat grows thick and clip frequently to maintain an even length. If the legs are clipped use standard blades, whereas the body may be clipped with standard or fine blades.

Cattle require coarse toothed blades.

Stretch the skin flat with the hand and as far as possible cut against the direction the coat grows. Glide over the skin with the blade.

Stop clipping at intervals to brush off the coat and oil the blades.

## TENSIONING THE CLIPPER BLADES (Fig. 1)

1. Wipe the head and blades (including between the teeth) absolutely clean.
2. Fit the blades on the clipper head and screw the tension nut down tight.
3. Turn the tension nut back 1½ turns. This is the correct setting. The tension nut marker line (A) will ensure accuracy.
4. Oil the blades and head, switch the clipper on and run briefly.
5. Switch off and wipe off any excess oil.

## LUBRICATION (Fig. 1)

Oil the moving parts before starting the motor. It is necessary to point the head up to allow oil to penetrate between cutter points, and sideways for effective lubrication of the blade rear surfaces.

1. Oil between cutter points
2. Oil clipper head front pads
3. Oil cutter blade guide channel
4. Oil cutter blade heel
5. Oil crank shaft and roller

Unlike other clippers, this model does not slow down appreciably when lubrication is required. Therefore, regular oiling of the blades is essential to keep them cool. If the blades get hot you are not oiling often enough or in the right places.

OIL EVERY 10 MINUTES RUNNING – Wipe off excess oil.

WARNING:- The use of spray lubricants is not recommended. Use Lister R15 oil, which is specially formulated for clipping.

## CARE OF BLADES

Blades should be kept together as MATCHED SETS.

The teeth could break if the blades are knocked. The steel blades, specially hardened for good cutting qualities, are more brittle than unhardened teeth.

## BLADE PROTECTION

WIPE BLADES ABSOLUTELY CLEAN. This is essential if the clipper is to work properly. The blades are ground and then lapped to a very fine precision finish.

## CLIPPING WITH NEW BLADES

New or reground blades must be cleaned, then tensioned correctly and oiled before use.

If the new blades fail to cut when first used, stop work immediately. DO NOT INCREASE THE TENSION - THIS CAN ONLY BE HARMFUL. Remove and clean the blades, as even a small amount of dirt or a single hair may be the cause of the trouble. Brush between the teeth and wipe the blades and head clean. Fit the blades back on to the clipper, then set the tension correctly and oil.

Should the clipper fail to cut again, repeat the cleaning procedure.

USE LISTER R15 OIL OR VERY LIGHT MACHINE OIL.

## FAILURE TO CUT

IF THE BLADES FAIL TO CUT – DO NOT INCREASE THE TENSION.

EXCESSIVE TENSION WILL ONLY CAUSE OVERHEATING AND WILL BLUNT THE BLADES.

THE CLIPPER WILL NOT CUT IF HAIR OR DIRT GETS BETWEEN THE BLADES

Remove the blades from the clipper. Wipe the clipper head clean to prevent stray hairs getting between the blades. Brush between the blade teeth and wipe the blades clean. Fit the blades back on the clipper. Finally set the tension correctly and oil.

THE SLIGHTEST BRUISE ON THE FACE OF EITHER BLADE IS SUFFICIENT TO STOP THEM CUTTING ALTOGETHER.

BLADES SHOULD BE KEPT TOGETHER AS MATCHED SETS.

WHEN THE BLADES HAVE LOST THEIR CUTTING EDGE RETURN THEM TO A QUALIFIED FIRM FOR REGRINDING.

## MAINTENANCE (Figs. 2 & 3)

It is particularly important to keep plug and cable clean and in good order at all times. The motor and drive gears can be expected to give years of trouble free use if maintained and serviced regularly. The following should be carried out at the end of each season, or more regularly if used extensively.

## GEARS (Fig. 2)

Every 200 hours running remove the clipper head (1). Wipe the clipper head and gearwheel (2) to remove hair and used grease. Coat the gearwheel with clean grease (Lister R2 or Shell Alvania R2 or equivalent). When the clipper head is removed, check the gearwheel for wear and broken teeth.

## FILTERS (Fig. 3)

The motor air filter shown in Fig. 3 should be frequently removed and meticulously cleaned (brush supplied) to ensure efficient running of the motor. To clear the gauzes, a high-pressure air-line is ideal – otherwise wash in detergent solution and dry carefully. If this maintenance is ignored, overheating of the motor could occur with possible irreversible damage to the motor, or inefficient clipping at the very least. DO NOT RUN MOTOR WITH FILTER REMOVED.

## CORD CARE

The cord should not be used to pull the clipper. Since freedom of movement needs to be maintained, care should be used to keep the cord untwisted and unobstructed. To reduce the risk of electric shock, this appliance has a polarized plug (one blade is wider than the other). This plug fits in a polarized outlet only one way. In the event the plug does not fit fully in the outlet, reverse the plug. In the event it still does not fit, contact a qualified electrician to install the proper outlet. Do not change the plug in any way.

**WARNING:** All maintenance should be carried out with the unit switched off and removed from the mains supply.

**RESET BUTTON (Fig. 3)**

The clipper is fitted with an overload protection switch, which will trip if the clipper is overloaded. Should this occur, the unit should be thoroughly checked before fully depressing the button to reset.  
The button is situated at the backend of the motor body (B).

**PARTS LIST (Fig. 4)**

When ordering spare parts please specify:

Part number, description and quantity of spare part(s).

Whenever possible, quote the Model and Clipper Serial Number which will be found on the specification plate.

Fig. 4 CLIPPER UNIT

Item No. Part No. = Description (No. per set)

- 1. 258-33560 = Motor 240V (1 per set)  
258-33920 = Motor 110V
- 2. 258-33573 = Clipper Casing R.H. (1 per set)
- 3. 258-33583 = Clipper Casing L.H. (1 per set)
- 4. 258-33750 = Gearshaft, Fan & Bearing Assembly (1 per set)(comprising items 5 – 10)
- 5. 258-33680 = Gearshaft Detail (1 per set)
- 6. 258-33690 = Gearshaft Insert (1 per set)
- 7. 258-33700 = Fan (1 per set)
- 8. 249-12250 = Ball Bearing (1 per set)
- 9. 258-32430 = Circlip (1 per set)
- 10. 258-31120 = O-ring (1 per set)
- 11. 258-33630 = Switch Lever (1 per set)
- 12. 258-37070 = Grommet (1 per set)
- 13. 258-33590 = Cable Clamp Bridge (1 per set)
- 14. 258-33670 = Screw (2 per set)
- 15. 258-33070 = Mains Lead UK (1 per set)  
258-33910 = Mains Lead USA  
258-33970 = Mains Lead AUS
- 16. 258-33650 = Printed Circuit Board 220-240V (1 per set) **FIG 1**  
258-33890 = Printed Circuit Board 110-115V
- 17. 258-33740 = Wrist Cord (1 per set)
- 18. 258-33730 = Wrist Cord End (1 per set)
- 19. 258-33660 = Upper Casing Screw (2 per set)
- 20. 258-33670 = Lower Casing Screw (3 per set)
- 22. 258-33961 = Filter (1 per set)
- 23. 258-33760 = Clipper Head Assy Complete (1 per set)  
(comprising items 24-30)
- 24. 258-33610 = Clipper Head (1 per set)
- 25. 258-30820 = Gear & Shaft Assembly (1 per set)
- 26. 258-00061 = Crank Head (1 per set)
- 27. 258-00057 = Crank Roller (1 per set)
- 28. 258-00062 = Crank Roller Spring (1 per set)
- 29. 258-30850 = Comb Peg (2 per set)
- 30. 258-30850P = Comb Peg Pin (2 per set)
- 31. 252-00009 = Tension Bolt (1 per set)
- 32. 258-10061 = Tension Spring (1 per set)
- 33. 258-33710 = Tension Nut (1 per set)
- 34. 258-34330 = Spring Clip (1 per set)

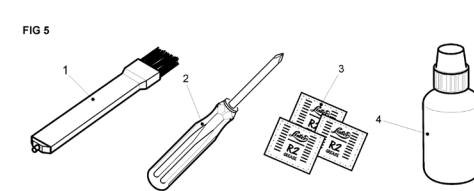
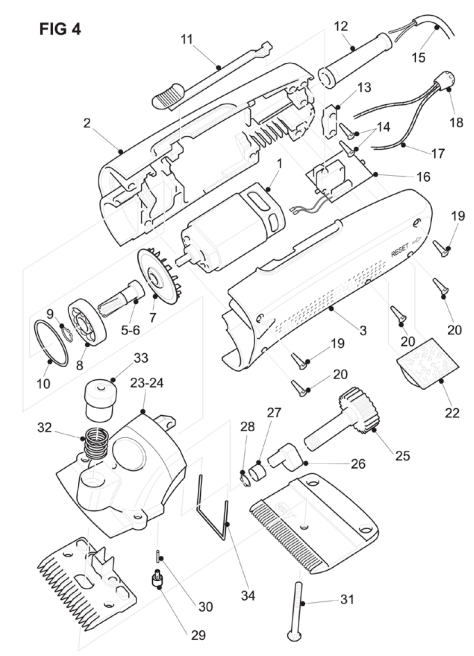
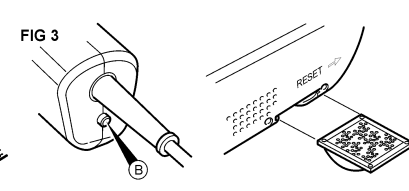
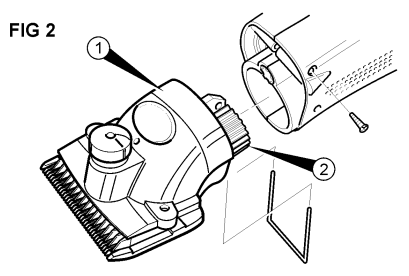
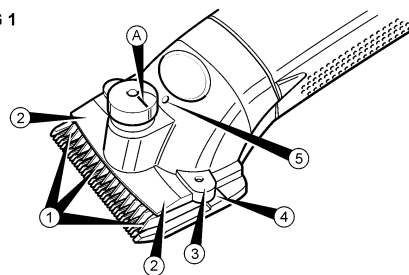

Wahl Clipper Corporation  
World Headquarters  
P.O. Box 578. Sterling, IL 61081

www.wahlglobal.com